

PARTS LIST									
ITEM	QTY	PART NO.	BOX NO.	PART DESCRIPTION	LENGTH	UNIT WT.	NET WT.		
1	2	P3160		3-1/2" X 160" SCH 40 GALVANIZED PIPE (A53 Gr.B Fy=35 ksi min.)	160 in	101.25	202.50		
2	2	PC312		3-1/2" FENCE POST CAP		0.59	1.17		
3	2	GRS12-10		12" WIDE GRIP STRUT	120 in	62.00	124.00		
4	4	HHD12-K	P-HHD12-K	HHD12-K (INV Model)		11.92	47.70		
5	6	UNT10-HFK		UNISTRUT H-FRAME KIT (120")		25.80	154.80		
6	8	G12R-6		1/2" x 6" GALV. THREADED ROD		0.33	2.68		
							TOTAL WT. #	532.84	

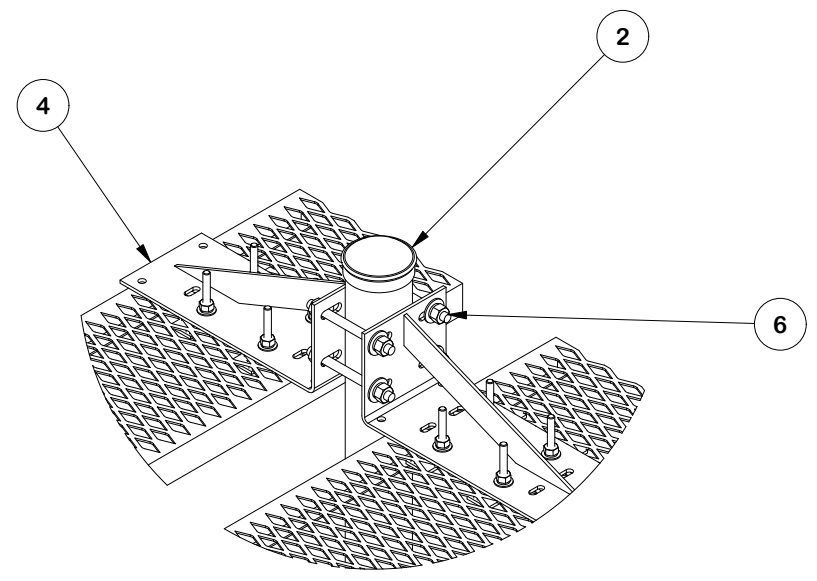

DETAIL A

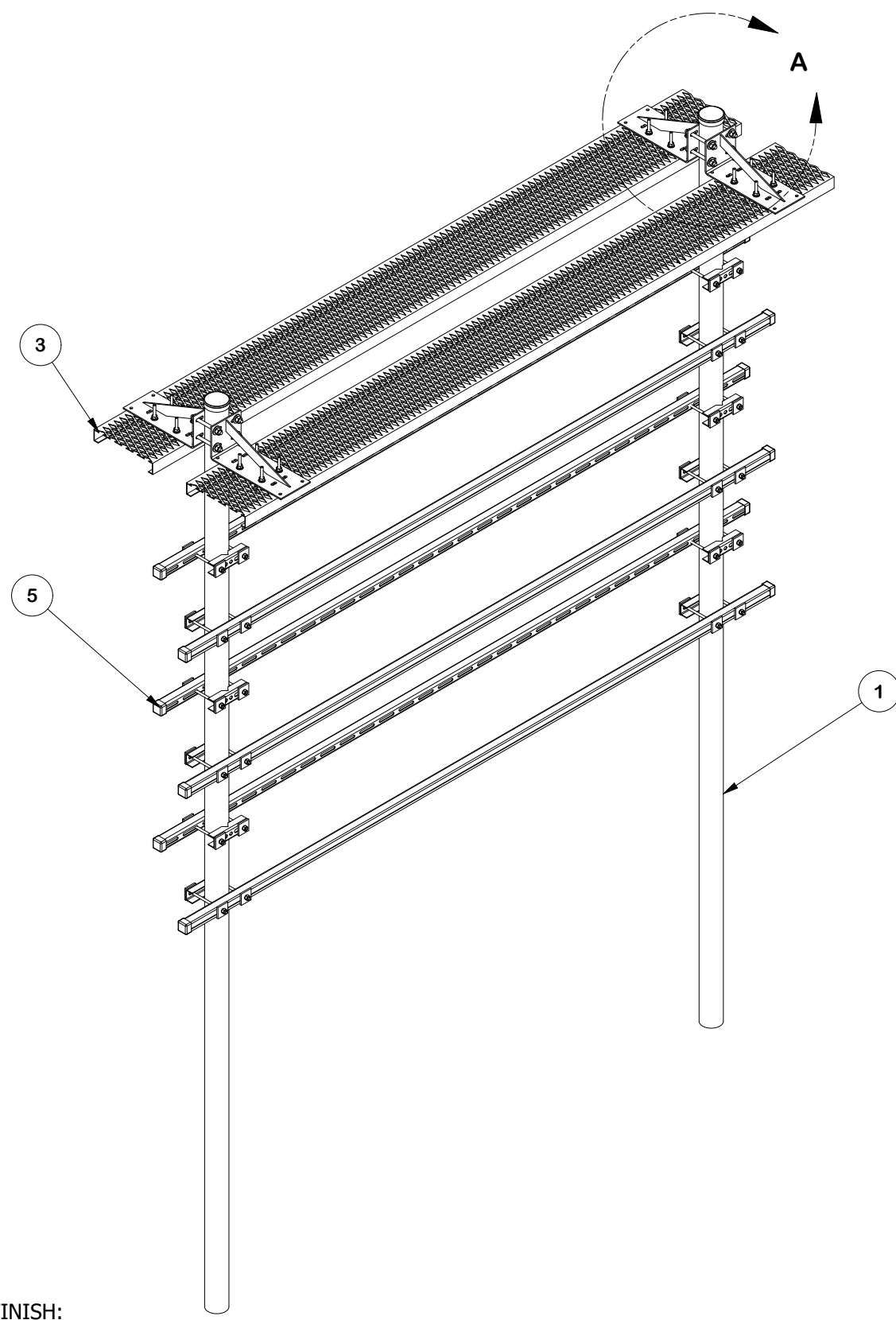
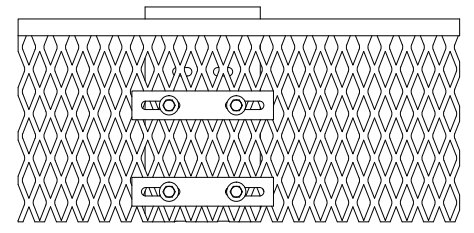

UNDERSIDE ATTACHEMENT

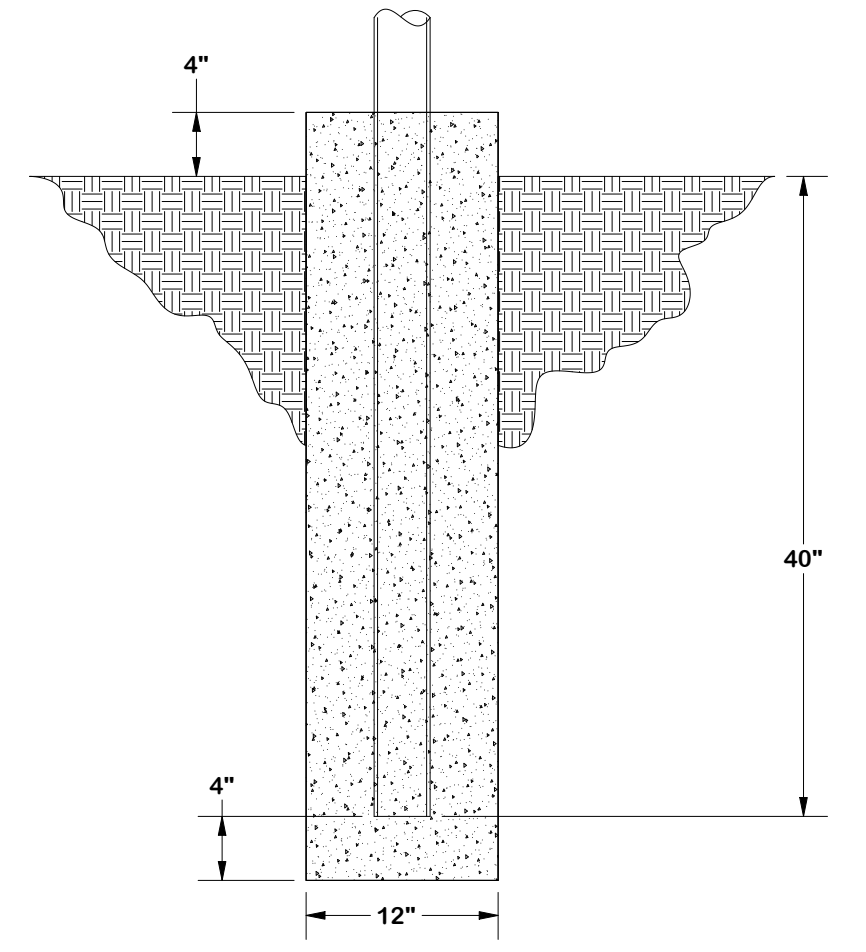

FINISH:
HOT DIP GALVANIZED.

REV	DESCRIPTION OF REVISIONS	CPD	BY	DATE
A	REVISED UNT10-HFK	SP1	SDR	7/11/2025

TOLERANCE NOTES
 TOLERANCES ON DIMENSIONS, UNLESS OTHERWISE NOTED ARE:
 SAWED, SHEARED AND GAS CUT EDGES ($\pm 0.030"$)
 DRILLED AND GAS CUT HOLES ($\pm 0.030"$) - NO CONING OF HOLES
 LASER CUT EDGES AND HOLES ($\pm 0.010"$) - NO CONING OF HOLES
 BENDS AND ANGLES ARE $\pm 1/2$ DEGREE
 ALL OTHER MACHINING ($\pm 0.030"$)
 ALL OTHER ASSEMBLY ($\pm 0.060"$)

PATENT INFORMATION: WWW.SITEPRO1.COM/PATENTS

PROPRIETARY NOTE:
 THE DATA AND TECHNIQUES CONTAINED IN THIS DRAWING ARE PROPRIETARY INFORMATION OF VALMONT INDUSTRIES AND CONSIDERED A TRADE SECRET. ANY USE OR DISCLOSURE WITHOUT THE CONSENT OF VALMONT INDUSTRIES IS STRICTLY PROHIBITED.

DESCRIPTION			
24" WIDE DUAL ICE-BRIDGE H-FRAME DIRECT BURIAL			
CPD NO.	DRAWN BY	ENG. APPROVAL	
SP1	SDR	1/15/2025	
CLASS	SUB	DRAWING USAGE	CHECKED BY
81	02	CUSTOMER	JET



Engineering Support Team:
sp1engineering@valmont.com

A valmont COMPANY

PART NO. **ERIB24D**

DWG. NO. **ERIB24D**

REV	DESCRIPTION OF REVISIONS	CPD	BY	DATE
A	REVISED UNT10-HFK	SP1	SDR	7/11/2025

PATENT INFORMATION: WWW.SITEPRO1.COM/PATENTS

PROPRIETARY NOTE:
 THE DATA AND TECHNIQUES CONTAINED IN THIS DRAWING ARE PROPRIETARY INFORMATION OF VALMONT INDUSTRIES AND CONSIDERED A TRADE SECRET. ANY USE OR DISCLOSURE WITHOUT THE CONSENT OF VALMONT INDUSTRIES IS STRICTLY PROHIBITED.

CPD NO.	DRAWN BY	ENG. APPROVAL	
SP1	SDR	1/15/2025	
CLASS	SUB	DRAWING USAGE	CHECKED BY
81	02	CUSTOMER	JET

PART NO.	ERIB24D
DWG. NO.	ERIB24D

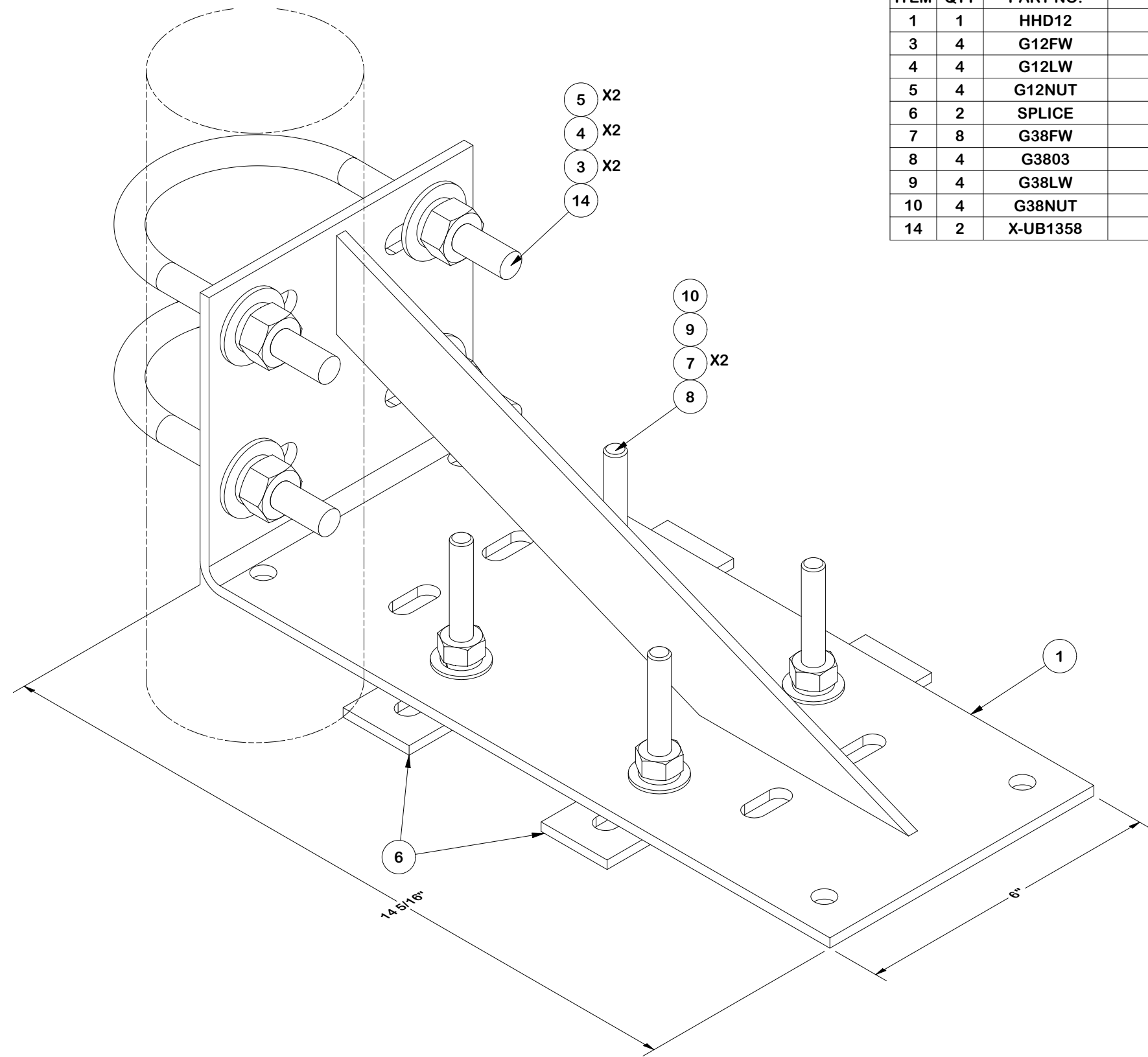

PARTS LIST						
ITEM	QTY	PART NO.	PART DESCRIPTION	LENGTH	UNIT WT.	NET WT.
1	1	HHD12	12" CANTILEVER WELDMENT		8.01	8.01
3	4	G12FW	1/2" HDG USS FLATWASHER	3/32 in	0.03	0.14
4	4	G12LW	1/2" HDG LOCKWASHER	1/8 in	0.01	0.06
5	4	G12NUT	1/2" HDG HEAVY 2H HEX NUT	7/8 in	0.07	0.29
6	2	SPLICE	SPLICE FOR GRIP STRUT	7 3/8 in	0.53	1.06
7	8	G38FW	3/8" HDG USS FLATWASHER		0.01	0.09
8	4	G3803	3/8" x 3" HDG HEX BOLT GR5		0.12	0.48
9	4	G38LW	3/8" HDG LOCKWASHER		0.01	0.03
10	4	G38NUT	3/8" HDG HEAVY 2H HEX NUT		0.03	0.14
14	2	X-UB1358	1/2" X 3-5/8" X 5-1/2" X 3" U-BOLT	5 1/2 in	0.82	1.64
					TOTAL WT. #	11.83

TOLERANCE NOTES

TOLERANCES ON DIMENSIONS, UNLESS OTHERWISE NOTED ARE:
 SAWED, SHEARED AND GAS CUT EDGES ($\pm 0.030"$)
 DRILLED AND GAS CUT HOLES ($\pm 0.030"$) - NO CONING OF HOLES
 LASER CUT EDGES AND HOLES ($\pm 0.010"$) - NO CONING OF HOLES
 BENDS AND ANGLES ARE $\pm 1/2$ DEGREE
 ALL OTHER MACHINING ($\pm 0.030"$)
 ALL OTHER ASSEMBLY ($\pm 0.060"$)

PATENT INFORMATION: WWW.SITEPRO1.COM/PATENTS

PROPRIETARY NOTE:
 THE DATA AND TECHNIQUES CONTAINED IN THIS DRAWING ARE PROPRIETARY INFORMATION OF VALMONT INDUSTRIES AND CONSIDERED A TRADE SECRET. ANY USE OR DISCLOSURE WITHOUT THE CONSENT OF VALMONT INDUSTRIES IS STRICTLY PROHIBITED.

DESCRIPTION
**24" WIDE DUAL ICE-BRIDGE H-FRAME
 DIRECT BURIAL**



Engineering Support Team:
 sp1engineering@valmont.com

CPD NO. SP1	DRAWN BY SDR 1/15/2025	ENG. APPROVAL 11/20/2025
CLASS 81	SUB 02	DRAWING USAGE CUSTOMER
CHECKED BY JET 11/20/2025		

PART NO. HHD12-K
DWG. NO. ERIB24D

PARTS LIST						
ITEM	QTY	PART NO.	PART DESCRIPTION	LENGTH	UNIT WT.	NET WT.
1	1	UNT10	UNISTRUT	120 in	20.38	20.38
2	2	UNICAP	UNISTRUT END CAP		0.03	0.06
3	2	X-UPC1	SMALL PIPE TO PIPE BRACKET	6 3/4 in	0.86	1.71
4	4	G38R-8	3/8" X 8" THREADED ROD (HDG.)		0.25	1.00
5	8	SQW38	3/8" SQUARE WASHER	2 in	0.29	2.31
6	8	G38LW	3/8" HDG LOCKWASHER		0.01	0.05
7	8	G38NUT	3/8" HDG HEAVY 2H HEX NUT		0.03	0.27
					TOTAL WT. #	25.82

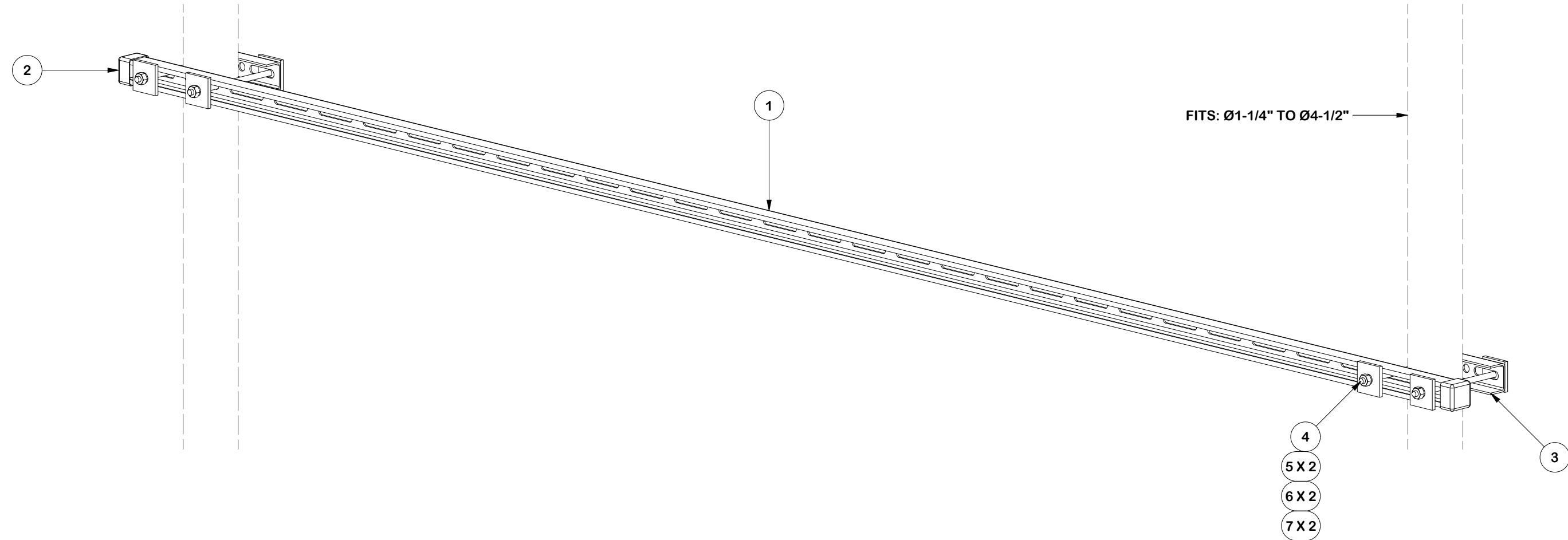

REV	DESCRIPTION OF REVISIONS	CPD	BY	DATE
A	CHANGED U-BOLT TO UPC1	SP1	SDR	6/20/2025
REVISION HISTORY				

TOLERANCE NOTES				
<p>TOLERANCES ON DIMENSIONS, UNLESS OTHERWISE NOTED ARE: SAWED, SHEARED AND GAS CUT EDGES ($\pm 0.030"$) DRILLED AND GAS CUT HOLES ($\pm 0.030"$) - NO CONING OF HOLES LASER CUT EDGES AND HOLES ($\pm 0.010"$) - NO CONING OF HOLES BENDS AND ANGLES ARE $\pm 1/2$ DEGREE ALL OTHER MACHINING ($\pm 0.030"$) ALL OTHER ASSEMBLY ($\pm 0.060"$)</p>				
PATENT INFORMATION: WWW.SITEPRO1.COM/PATENTS				
<p>PROPRIETARY NOTE: THE DATA AND TECHNIQUES CONTAINED IN THIS DRAWING ARE PROPRIETARY INFORMATION OF VALMONT INDUSTRIES AND CONSIDERED A TRADE SECRET. ANY USE OR DISCLOSURE WITHOUT THE CONSENT OF VALMONT INDUSTRIES IS STRICTLY PROHIBITED.</p>				

DESCRIPTION			
24" WIDE DUAL ICE-BRIDGE H-FRAME DIRECT BURIAL			
CPD NO.	DRAWN BY	ENG. APPROVAL	
SP1	SDR	11/15/2025	
CLASS	SUB	DRAWING USAGE	CHECKED BY
81	02	CUSTOMER	JET

 A valmont COMPANY		Engineering Support Team: sp1engineering@valmont.com	
PART NO.		UNT10-HFK	
DWG. NO.		ERIB24D	